

Garden valve, non-freezing  
 DN 15  $\varnothing$  Cu 15  
 Recommendation for dimensioning 0.2 l/s/160 kPa

- Wall mounted
- Vacuum breaker
- One inlet for cold or premixed water
- Frost proof

## TECHNICAL DATA

### TECHNICAL PROPERTIES

DN-size (nominal dimension)	DN15
Hot water supply	max. +80°C
Working pressure	50 - 1000 kPa
Connection size	$\varnothing$ 15 mm
Length / Height	450 - 1000 mm
Material	Brass

### APPROVALS AND DECLARATIONS

STF certificate	EUFI29-22000144-TH4
EPD	S-P-07816

### SUSTAINABILITY

EPD module A1-A3 (kg CO2 eq.)	8,09
EPD module A4 (kg CO2 eq.)	0,22
EPD module C2 (kg CO2 eq.)	0,02
EPD module C3 (kg CO2 eq.)	0,02
EPD module C4 (kg CO2 eq.)	0,10
EPD module D (kg CO2 eq.)	-5,89

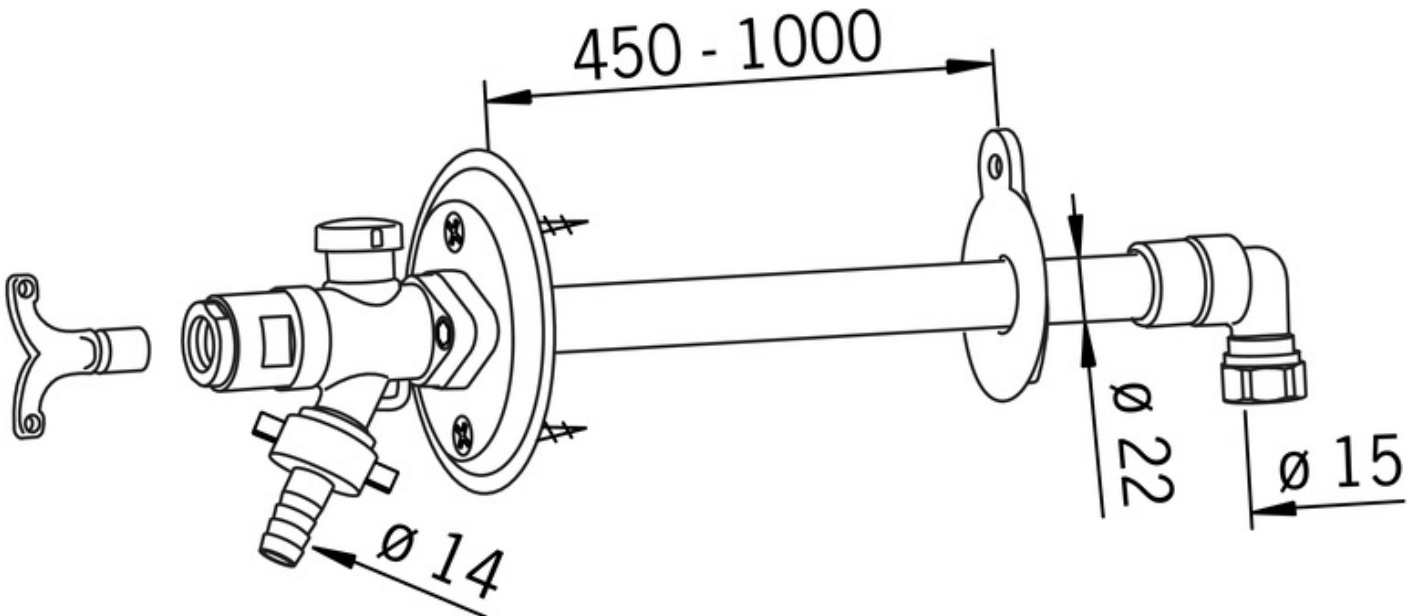

## SPARE PARTS

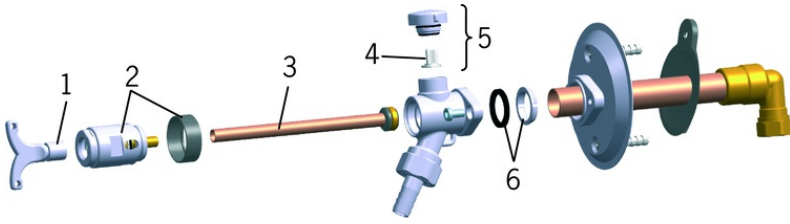

### SP431415

	Name	Code
01	Key	438126
02	Emptying valve	438382V
03	Inside spindle, 450 mm	438383V
03	Inside spindle, long, 1000 mm	438386V
04	Vacuum valve head	438124
05	Vacuum breaker	438090
06	Retainer bushing	438361V