



6662FTW ORAS ELECTRA SHOWER PANEL, 12

V WILL BE DISCONTINUED 7/2026

TOUCHLESS, EXTERNAL TRANSFORMER, THERMOSTATIC

EAN: 6414150077470 static.oras.com/6662FTW



Touchless thermostatic shower panel with hand shower and a temperature adjustment handle. Electrical connection 12 V via a separate transformer Oras 199275 (max 4 shower panels to one transformer). The shower is switched on by placing a hand in front of the sensor within the recognition range. Water will flow for as long as the person is standing under the shower. When the user exits the recognition range the water flow will stop automatically. The shower panel is equipped with litter filters, non-return valves, flow limiter and 10m power cable for transformer. Parameters are changed with a magnetic key included in the package. The following accessories are sold separately: soap holder (Oras No. 199880)

- Public & Semi-public
- Wall mounted
- Aluminium/Chrome
- Temperature control handle, Safety feature for water temperature
- Hand shower
- Safety stop against scalding at 38°C
- Thermostatic cartridge for automatic temperature control, Litter filter(s), Non-return valve(s)
- Autofocus infrared sensor, Solenoid valve
- Software settings adjustable via magnetic key

TECHNICAL DATA

FLOW PROPERTIES

Flow-rate at 300 kPa	0.18 l/s
Flow-rate at 300 kPa (with flow controller)	0.17 l/s
Pressure loss with flow (0.2 l/s)	350 kPa (70% qv = 171 kPa)

TECHNICAL PROPERTIES

Hot water supply	max. +70°C
Working pressure	100 - 1000 kPa
Connection size	G3/4
Installation width	150 mm
Backflow prevention (EN1717)	EB
Material	Aluminium

SOFTWARE SETTINGS

Afterflow period	5 s
Max. flow period	5 min
Opening range	0-5 cm

ELECTRONIC PROPERTIES

Electrical Connection	12 V
-----------------------	------

REGULATIONS

EU Directives	CE Low Voltage Directive 2014/35/EU , EMC Directive 2014/30/EU , RoHS Directive 2011/65/EU
EN standard	EN 1111 , EN 15091, ETSI EN 301 489-1 V1.9.2 , ETSI EN 300 328 v2.2.2 , EN 61000-6-1:2007 , EN 61000-6-3:2007+A1:2011+AC:2012 , EN 60335-1:2012+A11+A13+A14+A2+A15:2021, Part 19.11.4
Noise class	I (ISO 3822)
Protection class	IP 55

APPROVALS AND DECLARATIONS

Declaration of conformity	LVD
EPD	EPD-IES-0017638

SUSTAINABILITY

EPD module A1-A3 (kg CO2 eq.)	53,74
EPD module A4 (kg CO2 eq.)	0,40
EPD module B7 (kg CO2 eq.)	886,99
EPD module C2 (kg CO2 eq.)	0,01
EPD module C3 (kg CO2 eq.)	0,06
EPD module C4 (kg CO2 eq.)	0,00
EPD module D (kg CO2 eq.)	-0,43

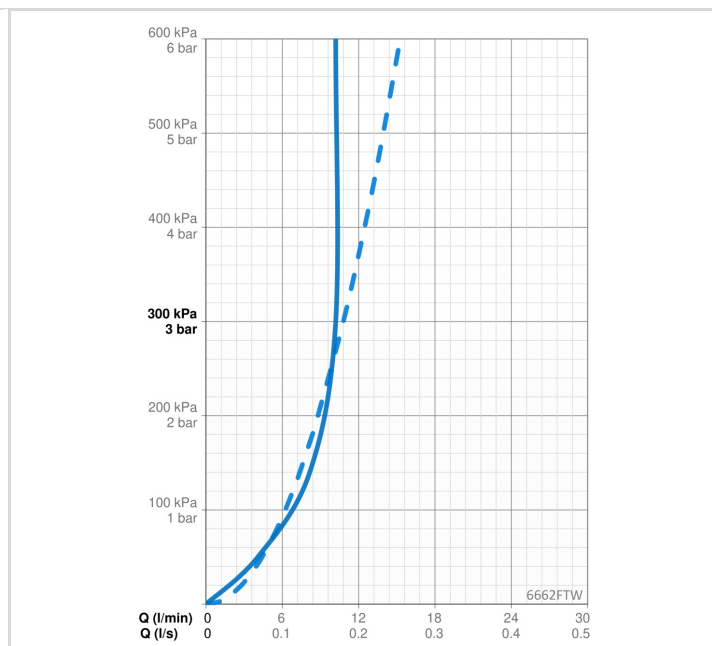
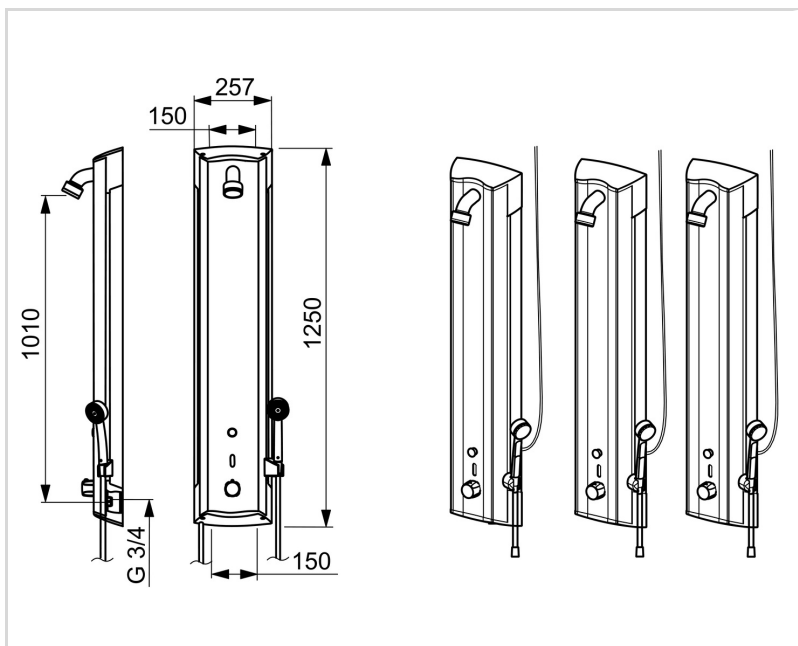

SPARE PARTS

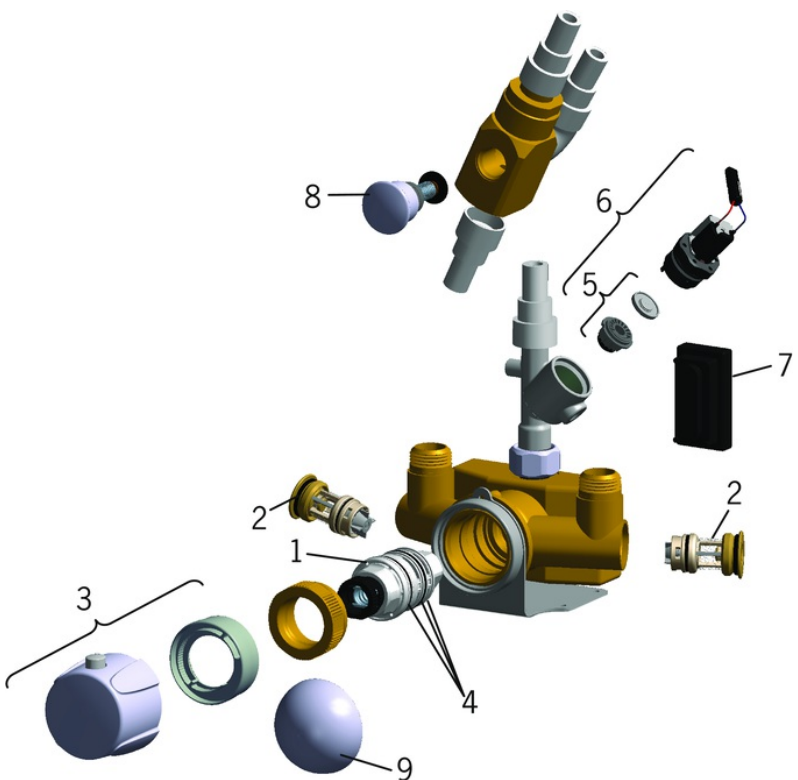

SP662FTW

Name	Code
01 Thermostatic cartridge	178780V
02 One-way valve with litter screen	178295
03 Temperature control handle Chrome	178794V
04 O-ring kit	178796V
05 Membrane support ring Discontinued	199205V
05 Membrane for solenoid valve	1006500V
06 Solenoid valve, 6 V	199206V
07 Sensor, 12 V	600203V
08 Diverter Chrome	209695
09 Protective cap Chrome	199276V