



# 7460C-33 ORAS NOVA ECO SHOWER FAUCET

THERMOSTATIC

EAN: 6414150100796 [static.oras.com/7460C-33](http://static.oras.com/7460C-33)



Thermostatic shower faucet. Temperature handle equipped with safety stop at 38°C. Volume handle with Eco Flow control. The faucet includes litter filters and non-return valves.

- Wall mounted
- Matt black
- Temperature control handle, Flow control handle, Eco feature for water flow, Safety feature for water temperature
- Eco flow control
- Safety stop against scalding at 38°C, Temperature preset fixable
- Ceramic head part for flow control, Thermostatic comfort cartridge for precise temperature control, Non-return valve(s), Litter filter(s)
- Direct connection, Internal thread, Cover plate(s)

## TECHNICAL DATA

### FLOW PROPERTIES

Eco-flow at 300 kPa	0.19 l/s
Flow-rate at 300 kPa	0.27 l/s
Pressure loss with flow (0.2 l/s)	165 kPa

### TECHNICAL PROPERTIES

Hot water supply	max. +80°C
Working pressure	100 - 1000 kPa
Connection size	G3/4
Installation width	150 mm
Backflow prevention (EN1717)	EB
Material	Brass

### REGULATIONS

EN standard	EN 1111
Noise class	I (ISO 3822) Oras lab.

### APPROVALS AND DECLARATIONS

STF certificate	EUF129-22005199-TH
KIWA SE	1598
Declaration of conformity	DoC
EPD	S-P-06397

### SUSTAINABILITY

EPD module A1-A3 (kg CO2 eq.)	9,66
EPD module A4 (kg CO2 eq.)	0,35
EPD module B7 (kg CO2 eq.)	2004,50
EPD module C2 (kg CO2 eq.)	0,02
EPD module C3 (kg CO2 eq.)	0,02
EPD module C4 (kg CO2 eq.)	0,69
EPD module D (kg CO2 eq.)	-6,13

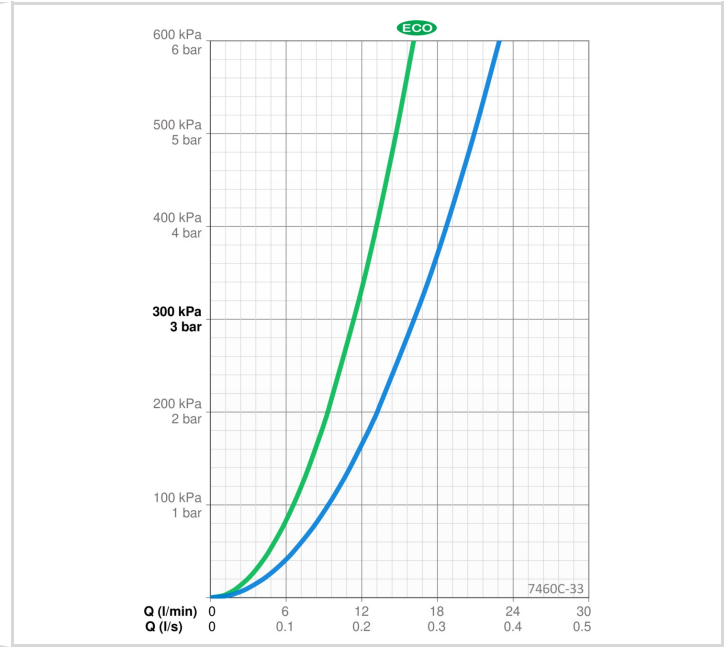
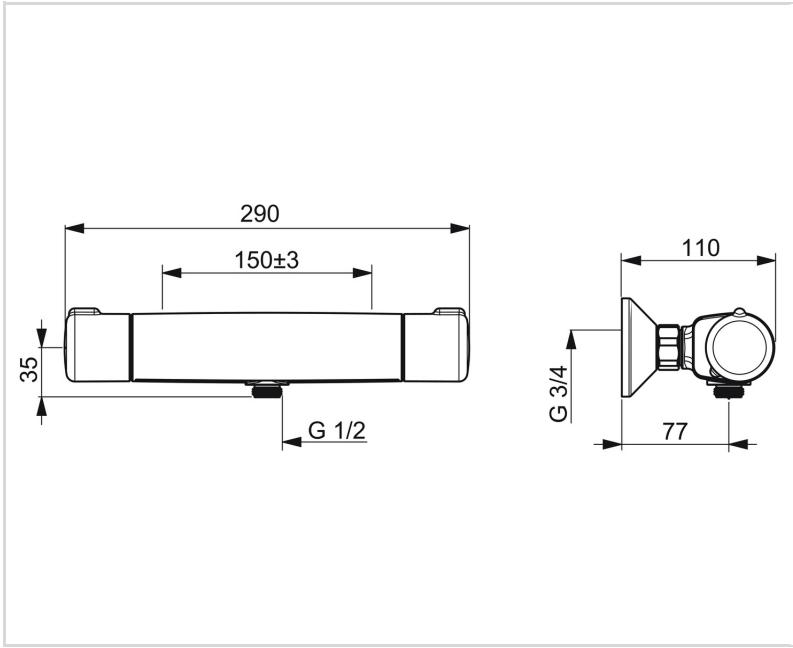

**SPARE PARTS**

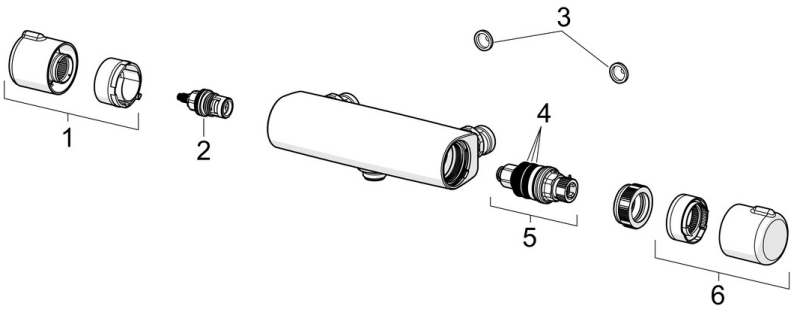

**SP7460C-33**

Name	Code
01 Flow control handle Matt black	1014422V-33
02 Headpart Chrome	109898
03 Filter sealing, G3/4, DN20	178375V
04 O-ring kit	178796V
05 Thermostatic cartridge	1008762V
06 Temperature control handle Matt black	1008607V-33